

(#4843)  
**THE VILLAGE AT WILDCREEK**  
A CONDOMINIUM SUBDIVISION  
A POR. OF THE E 1/2 OF SEC. 31,  
AND A POR. OF THE W 1/2 OF SEC. 32,  
T20N - R20E

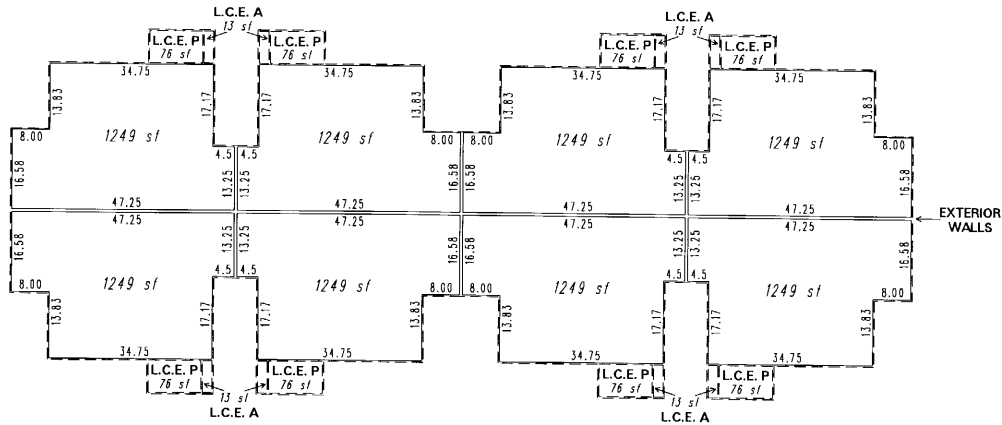

(1 STORY BUILDINGS)  
**FLOOR PLAN D**  
**BUILDINGS 10 & 11**

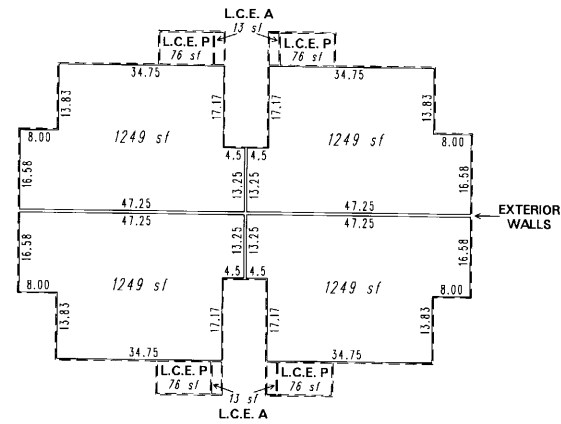

(1 STORY BUILDINGS)  
**FLOOR PLAN D**  
**BUILDINGS 8 & 9**

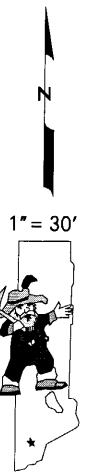

L.C.E. A = LIMITED COMMON ELEMENT STORAGE  
L.C.E. P = LIMITED COMMON ELEMENT PATIO

NOTE: This map is prepared for the use of the Washoe County Assessor for assessment and illustrative purposes only. It does not represent a survey of the premises. No liability is assumed as to the sufficiency or the accuracy of the data delineated hereon.

**BUILDING DETAILS**

*Office of Washoe County Assessor, Nevada - Joshua G. Wilson*

This area previously shown on \_\_\_\_\_ 027-20 \_\_\_\_\_

NOTE: Areas of parcels which are less than 2 acres are shown in square feet.

Drawn by NLH 01/02/08  
Revised \_\_\_\_\_  
ARC/INFO 9.2 WINDOWS 2000 5.0