

027-55-S3

027-55-S9

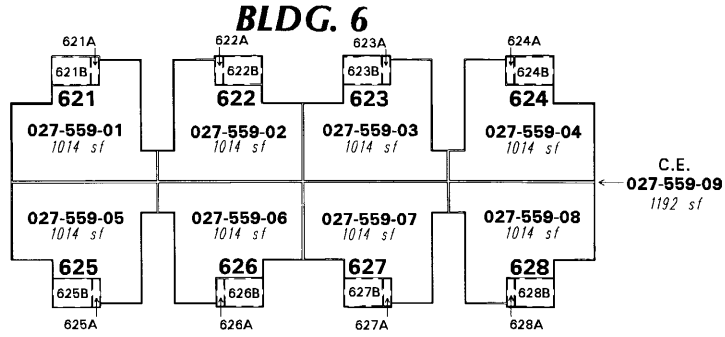

(#4843)
THE VILLAGE AT WILDCREEK
 A CONDOMINIUM SUBDIVISION

A POR. OF THE E 1/2 OF SEC. 31,
 AND A POR. OF THE W 1/2 OF SEC. 32,
 T20N - R20E
 (SECOND FLOOR)

559

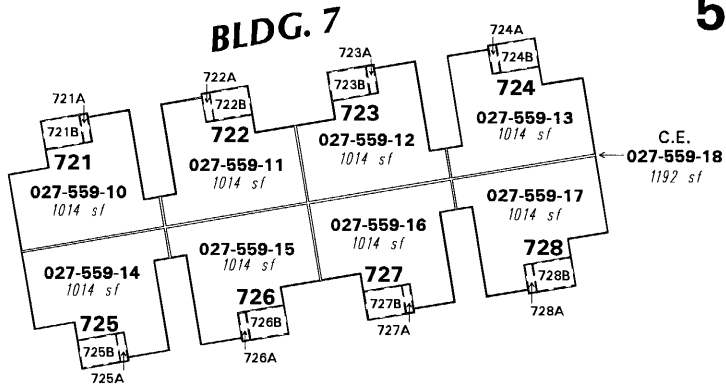

027-55-S3

027-55-S3

027-55-S3

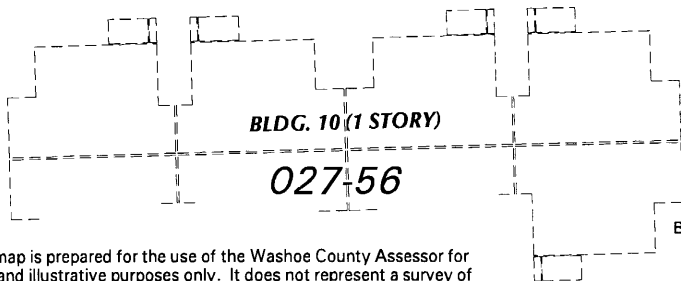
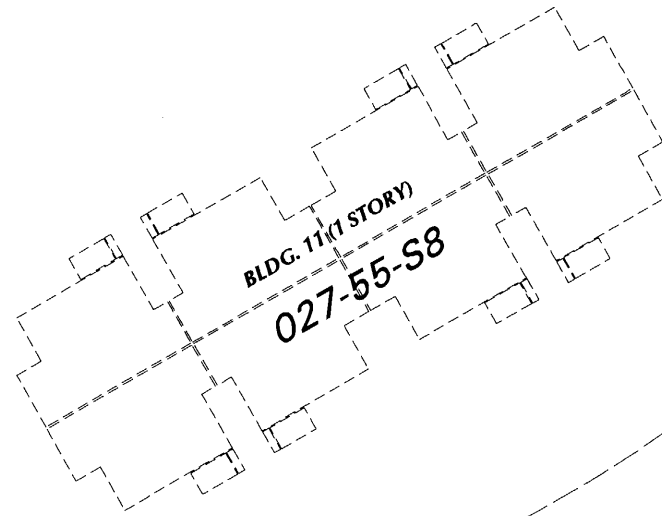

NOTES

SEE PAGES 027-55 thru 027-55-S2 FOR BUILDING DETAILS AND DIMENSIONS

SEE PAGE 027-55-S3 FOR BUILDING OVERVIEW

SEE PAGE 027-55-S8 FOR FIRST FLOOR

C.E. = COMMON ELEMENT

L.C.E. = LIMITED COMMON ELEMENT

L.C.E. KEY

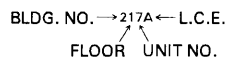

UNIT NO. KEY



027-55-S3

This area previously shown on 027-20

NOTE: This map is prepared for the use of the Washoe County Assessor for assessment and illustrative purposes only. It does not represent a survey of the premises. No liability is assumed as to the sufficiency or the accuracy of the data delineated herein.

Office of Washoe County Assessor, Nevada - Joshua G. Wilson

NOTE: Areas of parcels which are less than 2 acres are shown in square feet.

Drawn by NLH 01/07/08
 Revised

